

## RVK-40 – DESIGN FORMULAS AND DEFINITIONS

The following information indicates a rational method for design of anchorage of the RVK-40 into concrete slab structures. Design formulas conform to ACI and PCI and represent a method of analysis based on past experience and acceptable engineering practice.

The RVK connection system is a proprietary structural component that the Engineer-of-Record (EOR) specifies for a concrete slab end section. The design method presented in this reference is intended only as a guide for the EOR's consideration. Neither JVI nor any of its consultants or suppliers have any EOR responsibility, or responsibility for Contractor use or application of the RVK connection system.

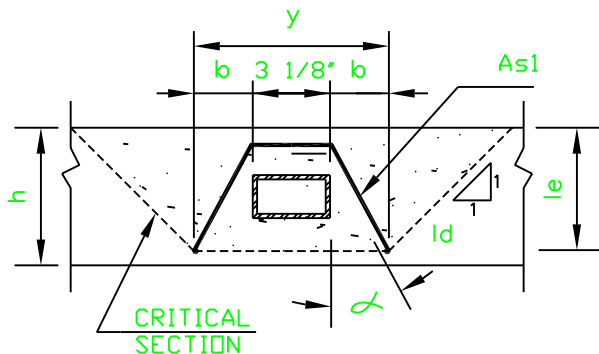

SECTION THROUGH As1

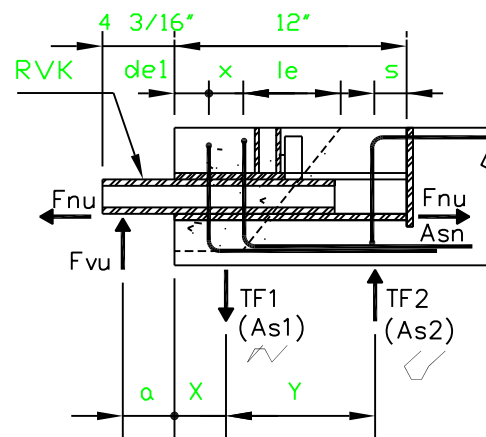

END ELEVATION

$$TF1 = Fvu(a+X+Y)/Y$$

$$TF2 = TF1 - Fvu$$

$$As1 = TF1 / (ofy(\cos \alpha))$$

$$As2 = TF2 / (bfy(\cos \alpha))$$

$$hmin = (z+2le)/2 \text{ where } z \text{ is lesser of } x \text{ and } y$$

$$\phi P_c = \phi 2.67 \lambda \sqrt{f'_c} (x+le+de1)(y+2le) \text{ PCI Design Handbook, Chapter 6}$$

### DEFINITIONS AND NOTES

a = Distance from face of slab to support reaction

de1 = Edge distance to first hanger bar in As1

x = Distance to last hanger bar in As1

le = Effective length of As1 to full anchorage

b = Distance from face of RVK to anchorage location in hanger reinforcement

y = Overall dimension for group anchorage of hanger reinforcement.

s = Distance from end of RVK to As2 bar (one bar assumed)

Fvu = Vertical support load

Fnu = Horizontal support load (recommended minimum = .2Fvu)

TF1 = Vertical equilibrium tension force on slab, requiring "hanger" reinforcement As1

TF2 = Vertical equilibrium tension force on slab, requiring "hanger" reinforcement As2

X = Distance from end of slab to TF1

Y = Distance between TF1 and TF2

ld = Development length of As1 (As2 sim) beyond critical section for required forces

Pc = Nominal strength of concrete against vertical tension force TF1

alpha = Angle of hanger reinforcement with vertical

lambda = Coefficient for use with lightweight concrete

phi = 0.85 typical per PCI recommendations

The above example is for an edge distance adequate to develop the full pullout capacity of the concrete as indicated (edge of RVK to edge of slab no less than b+le).

For smaller edge distances, see the PCI Design Handbook, Chapter 6.

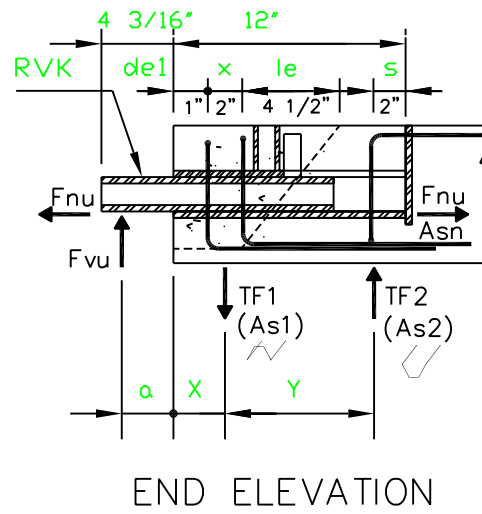
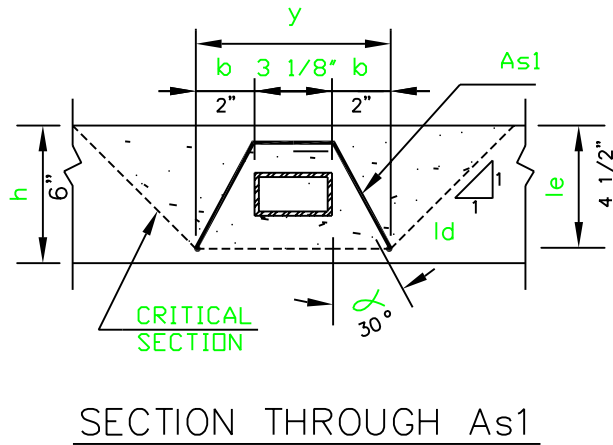

The following design example is to illustrate a typical application of the RVK-40 stair connection. The design example is for the maximum design capacity of 9 kips for the RVK-40.

GIVEN:

SLAB DATA

$F_{vu} = 9$  kips  
 $F_{nu} = 0.2F_{vu} = 1.8$  kips  
 $f'_c = 5000$  psi (normal weight)  
 $h = 6''$   
 Joint = 1"

REINFORCEMENT

$f_y = 60$  ksi  
 $b = 2''$   
 $l_e = 4.5''$   
 $\alpha = 30^\circ$   
 $de1 = 1''$   
 $x = 2''$   
 $s = 2''$

Calculate geometric properties in order to obtain TF1 and TF2:

$$a = \text{joint size} + (4 \frac{3}{16} - \text{joint size}) / 2$$

$$a = 1 + (4.1875 - 1) / 2 = 2.59''$$

$$X = 1 + 2 / 2 = 2''$$

$$Y = 12 - 2 - 2 = 8''$$

Summing moments about TF2:

$$TF1 = 9x(2.59 + 2 + 8) / 8 = 14.2 \text{ kips}$$

$$TF2 = 14.2 - 9 = 5.2 \text{ kips}$$

Therefore:

$$As1 = 14.2 / (.85(60)\cos 30^\circ) = .32 \text{ sq in} \quad 2\text{-}\#3 \checkmark = .44$$

$$As2 = 5.2 / (.85(60)\cos 30^\circ) = .12 \text{ sq in} \quad 1\text{-}\#3 \checkmark = .22 \text{ --OK}$$

$$An = 1.8 / (.85(60)) = .035 \text{ sq in} \text{ -- check existing slab reinforcement --OK}$$

Check concrete strength vs. TF1:

$$y = 3.125'' + 2(2'') = 7.125''$$

$$h_{min} = (z + 2l_e) / 2 \text{ where } z \text{ is lesser of } x \text{ or } y \text{ (PCI Design Handbook, Chapter 6)}$$

$$h_{min} = (2 + 2(4.5)) / 2 = 5.5'' \text{ less than } h = 6'' \text{ --OK}$$

$$\phi P_c = .85(2.67)(1) \sqrt{5000}(2 + 4.5 + 1)(7.125 + 2(4.5)) / 1000 = 19.4 \text{ kips } TF1 = 14.2 \text{ kips --OK}$$

The designer should note that the concrete strength requirements to resist TF2 have not been illustrated here, since they will not govern this design application.

The designer must consider all conditions related to the specific application of the RVK-40, since specific conditions will dictate actual strength requirements.